

Graymills

Model BIO436R-A and BIO536R-A BIOMATIC[®] Heated Bioremediation Parts Cleaner

Operations and Maintenance Instructions

Be sure anyone operating this unit reads and understands all warnings and instructions. Keep this manual available for reference/training.

SAFETY WARNINGS

You will find various types of safety information on the following pages and on the labels attached to Graymills equipment. The following Safety Statements explain their meaning:



This is the safety alert symbol. It is used to alert you to potential personal injury hazards. Obey all safety messages that follow this symbol to avoid personal injury or death.



DANGER indicates a hazardous situation which, if not avoided, will result in death or serious injury.



WARNING indicates a hazardous situation which, if not avoided, could result in death or serious injury.



CAUTION, used with the safety alert symbol, indicates a hazardous situation which, if not avoided, could result in minor or moderate injury.



CAUTION, without the safety alert symbol, is used to address practices not related to personal injury.

READ BEFORE OPERATING



- Use only Super Biotene[™] cleaning fluids. Do NOT use solvents, gasoline, etc., as they will create an extremely hazardous situation.
- Do NOT contaminate cleaning fluid with any flammable or combustible material such as gasoline, alcohol, mineral spirits, etc. Drain parts to be cleaned of any flammable material or combustible material before cleaning. Even small quantities can create a dangerous fire hazard.



- Never work with equipment you feel may be unsafe. Contact your supervisor immediately if you feel a piece of equipment is in unsafe condition.
- Cleaning solutions may be irritating to skin and eyes. Always wear gloves, apron and safety glasses when using. If splashed in eyes, flush thoroughly with water and follow directions on cleaning solution MSDS. See "USE OF INDUSTRIAL CLEANING SOLUTIONS" on page 2.
- Install machine in a well ventilated area.

⚠ CAUTION

- The unit has been factory set to maintain an optimum temperature for the microbes. Do NOT attempt to change thermostat setting.
- This is a heated system. Always use caution when first putting hand under liquid stream to prevent injury from heated solution. If the liquid feels uncomfortably hot, discontinue use, unplug machine and call Graymills Customer Service.
- Failure to keep proper liquid level will result in burning out the pump and heater coil, creating a potential fire hazard. To help prevent this, this unit is equipped with a low liquid level device which will shut off the pump and heater. If solution stops circulating and the red "RESET" light becomes illuminated, immediately turn off and unplug unit. For instructions on filling the reservoir, please see "INSTALLATION AND OPERATION" steps 6 through 9.

BIO436R Only

- After extended use, the gas-spring used to assist in opening and closing the lid may lose its ability to keep the lid open. At the first sign of this, replace the gas-spring immediately.
- Automatic Safety Cover. Since certain soils may be combustible, e.g., oils, greases, this unit is equipped with a fusible safety link cover mechanism designed to support the open cover at a slightly forward angle. In the event of a fire, the fusible link will melt at 165°F permitting the cover to slam shut, limiting oxygen supply to the fire.
- Do not leave the unit unattended with parts in the tank which would prevent the cover from closing completely in the event of a fire. Keep cover closed when unit is not in use. If the fusible link breaks, do not operate the unit until a replacement link is installed.

CAUTION

- DO NOT leave the unit disconnected without power for extended periods of time (overnight or weekends). This will cause the microbes to go dormant. This will adversely affect the bioremediation process. If microbes do not reactivate after operating temperature has been reached, a new BIO-POUCH should be added.
- If unit is to be unused, but not unplugged or turned off, for extended periods (overnight and weekends), it may be necessary to top-off tank to the 30-gallon mark with pre-blended Super Biotene™ cleaning solution to prevent the machine from shutting down due to low liquid levels.

POWER SUPPLY, WIRING AND GROUNDING

⚠ WARNING

- Failure to permanently ground the unit and controls before connecting to electrical power can cause shock, burns or death.
- Install ground and wiring according to local and national electrical code requirements.
- Install a fused disconnect switch on all power legs near the unit
- Disconnect and lockout electrical supply before installing or servicing unit.
- Unit must be properly grounded to prevent electric shock hazard. Connect only to three-prong outlet. Should cord become cracked, frayed or damaged in any way, it should be repaired/replaced immediately by a qualified electrician. Never use an extension cord. (See Spare Parts List)
- The full-load amperage draw for this machine is 12 amps.

USE OF INDUSTRIAL CLEANING SOLUTIONS

⚠ WARNING

- Always wear the recommended safety apparel and glasses.
- Adequate ventilation should be provided when operating this unit.
- When making an initial batch of cleaning solution or when adding compound, follow cleaning solution's directions exactly.
- Industrial cleaning solutions may be irritating to some individuals. Be certain to consult the MSDS for the cleaning solution you are using before filling or using parts washer.
- If splashed in the eyes, follow cleaning solution MSDS instructions.
- If cleaning solution is splashed on clothing, remove promptly and thoroughly wash any body areas which have been in contact with solution. DO NOT permit saturated clothing to remain in contact with skin. Consult cleaning solution's MSDS instructions.
- Clean up fluid spills immediately. Super Biotene™ can create a slippery surface. Also, the microbes metabolize organic materials and could damage floor coverings or painted surfaces.

CAUTION

- Graymills strongly recommends that federal, state and local authorities be consulted before proceeding with discarding and handling of used materials. Graymills Corporation accepts no responsibility for user's failure to comply with regulations.
- For best results, Graymills' recommends using only Super Biotene™ 550 (concentrate) or Super Biotene™ 660 (pre-blended).

MACHINE INSTALLATION AND OPERATION

1. Place unit on a smooth, level surface in a well ventilated area.
2. Install backslash as show to the right (BIO536R only).
3. Read all warnings posted on machine.
4. Inspect electrical control box, cord and plug for wear or damage.

WARNING

Do not use machine or add fluid if any wear or damage is noticed until impaired components are repaired or replaced.

5. Install filter cartridge:
 - a. Unscrew filter cartridge bowl.
 - b. Remove clear plastic packaging from new filter cartridge and remove BIO-POUCH from hollow center of cartridge.
 - c. Install new filter cartridge in the cartridge bowl.
 - d. Re-attach filter cartridge bowl to filter body.

CAUTION

Be sure electrical cord is unplugged and cleaning solution and heater coil is cool before adding cleaning solution or performing any maintenance.

6. Remove center sink drain (stainless steel strainer basket, mesh strainer assembly).
7. Add 30-gallons of Super Biotene™ solution to the base reservoir tank.
8. Add one (1) BIO-POUCH of microbes to tank, found inside filter cartridge.
9. Put center sink drain assembly back into sink drain opening.
10. Plug power cord into properly grounded 115V, 15 amp circuit. Full load amp-draw of unit is 12 amps.
11. Press TEST button on GFCI on rear of control (right) to ensure switch is operating properly. Press RESET button on GFCI to prepare unit for operation.
12. Air pump will begin operation immediately upon power being applied to the machine and the red "RESET" light will illuminate.
13. Toggle RESET switch located under the electrical box to begin operation. If the unit has an adequate level of cleaning solution in the tank, the green "READY" light will illuminate and the red "RESET" light will extinguish.
14. The amber "HEAT" light indicates power to the heater.
15. If cleaning solution is not at the appropriate temperature and heat is required you should hear the thermostat engage with a "CLICK" and the amber "HEAT" light will illuminate. Should this not happen, press the red thermostat reset button on the rear of the control box (right). Should this problem persist: unplug machine and call factory.
16. When the unit reaches its predetermined temperature, the "HEAT" light will extinguish, indicating the cleaning solution is at the proper temperature to obtain maximum cleaning efficiency. For maximum cleaning efficiency, allow heater to warm solution for 2 to 4 hours before use.
17. To operate the fluid pump, toggle PUMP switch on front of electrical box to the "ON" position.
18. For fluid via the flexible hose turn the directional valve counterclockwise to the left.
19. For fluid via the flow-thru brush turn the directional valve clockwise to the right.

CAUTION

When not in use return flow-thru brush to brush clip holder to holder to avoid obstructing lid closure (BIO436R only).

20. **Failure to keep proper liquid level will result in burning out the pump and heater coil, creating a potential fire hazard.** To prevent this, this unit is equipped with a low liquid level device which will shut off the pump and heater. If solution stops circulating and the red "RESET" light becomes illuminated, immediately turn off and unplug unit. Follow steps 6 through 9 above for instructions on refilling unit.

CAUTION

21. When finished, turn pump off and close lid to minimize liquid loss due to evaporation (BIO436R only). Do NOT unplug the machine for extended periods of time. The internal air pump and heaters are necessary for effective bioremediation. This will cause the microbes to go dormant and will adversely affect the bioremediation process. If microbes do not reactivate after operating temperature has been reached, a new BIO-POUCH should be added.

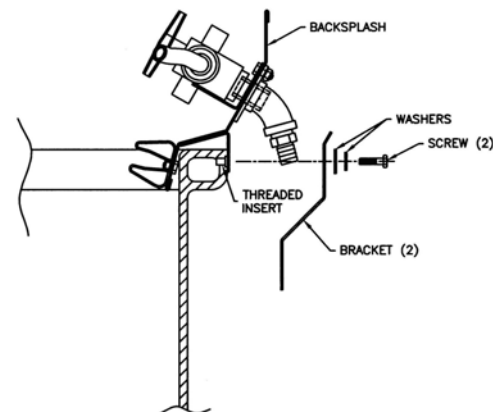

Backslash Assembly for BIO536R-A

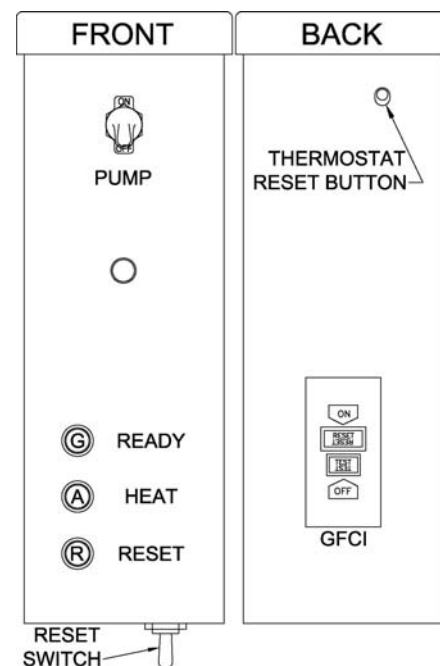

**Operator Interface
BIO436R-A and BIO536R-A
Front and Back**

RECOMMENDED NORMAL MAINTENANCE

CAUTION

Be sure electrical cord is unplugged and cleaning solution and heater coil is cool before performing any maintenance.

1. Check fluid level in unit daily.
2. Due to evaporation and drag-out, fluid should be topped off with Super Biotene™ cleaning solution as needed.
3. A new BIO-POUCH should be added to cleaning solution in tank reservoir every 30-40 days.
4. Inspect strainer basket daily. Remove and dispose of solid waste accumulation. To assure proper drainage rinse out vapor barrier filter daily.
5. Check operation of liquid level control. Make sure that float switch moves freely up and down.
6. Unit is equipped with a blue temperature-sensitive label on the front of the reservoir. When solution is heated, the temperature change will cause the label to change from blue to pink. The change will occur only at or below the liquid level, allowing the level to be determined without having to look through the drain or remove the sink.

CAUTION

When control assembly is removed from reservoir, care must be taken not to damage components.

7. Inspect heating coil monthly, remove any deposits or build up with a soft wire brush.

CAUTION

Deposits and build up can cause premature failure of the heating coil.

8. Filter cartridge will require periodic replacement depending on the volume and types of soils involved. A significant reduction in the flow through the flexible hose signals the need to replace the cartridge (see RECOMMENDED ANNUAL MAINTENANCE). Order replacement cartridges, part number BIOFL1, from either your Graymills distributor or the factory.
9. After extended use, the gas spring used to assist in opening and closing the lid on model BIO436R may lose its ability to keep the lid open. At the first sign of this, replace the gas spring immediately. Order part number 765-09631.

RECOMMENDED ANNUAL MAINTENANCE

Graymills recommends that the entire system be inspected and cleaned annually. To perform this maintenance:

CAUTION

Be sure electrical cord is unplugged and cleaning solution and heater coil is cool before performing any maintenance.

1. Remove sink drain filters and rinse.
2. Clean filter cartridge assembly:
 - a. Unscrew filter cartridge bowl.
 - b. Pour liquid from filter bowl into reservoir.
 - c. Remove filter cartridge and dispose of in proper manner.
 - d. Remove clear plastic packaging from filter cartridge and remove BIO-POUCH from hollow center of cartridge.
 - e. Install new filter cartridge in the cartridge bowl.
 - f. Re-attach filter cartridge bowl to filter body.
3. Unscrew sink hold downs.
4. Lift sink straight up until mounting ring clears reservoir and set to the side.
5. Lift off control assembly being careful not to damage heater, float switch or pump.

CAUTION

When control assembly is removed from reservoir, care must be taken not to damage components.

6. Visually inspect pump, pump inlet filter, heater float switch, and tubing for damage or wear.
7. Replace all parts as necessary. Make sure all "tie-offs" for pump, heater and float switch are still in place insuring proper separation and alignment of these components.
8. Clean excess accumulation off heater coil with a soft wire brush.
9. Inspect surface of cleaning solution and skim to remove any oil, bio-mass or debris.
10. Pump cleaning solution into acceptable container for future reuse.
11. Rinse inside of reservoir tank with clean water.
12. Refill reservoir tank with saved solution from step 10.
13. If necessary, top-off cleaning solution with enough fresh Super Biotene™ cleaning solution to bring reservoir up to 30-gallon mark.
14. Add a BIO-POUCH to cleaning solution
15. Replace control assembly and sink.
16. Follow steps 8 through 14 in MACHINE INSTALLATION AND OPERATION to complete annual maintenance.

Save this manual for future training. Do not allow operation without reading and understanding these instructions.

TROUBLESHOOTING

Problem	Probable Cause	Suggested Remedy
No Machine Function	Machine unplugged	Plug machine into appropriate wall socket
	GFCI tripped	Press RESET button on GFCI
	No power at outlet	Consult plant electrician
Heat Not Working	Thermostat tripped	Press red thermostat reset button
	Heater malfunction	Contact Graymills for more information 1-888-472-9645
	Heater coil dirty	Clean heater coil (see Recommended Maintenance)
Red "RESET" Light ON	Machine needs to be reset	Toggle RESET switch
	Low solution level	Add cleaning solution
	Float sensor or control relay malfunction	Contact Graymills for more information 1-888-472-9645
Little or No Fluid Flow	Valve shut off	Turn valve fully to the left or right to open valve
	Clogged filter	Replace filter cartridge (Part #BIOFL1)
	Cracked or broken hose	Inspect and replace hose (See parts list)
Bioremediation No Longer as Effective	Expired microbes	Add BIO-POUCH to tank solution

If your problem is not listed above or problems persist, please contact Graymills for further assistance. 1-888-472-9645

DRAWINGS AND PARTS LISTS

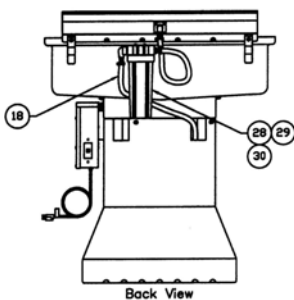
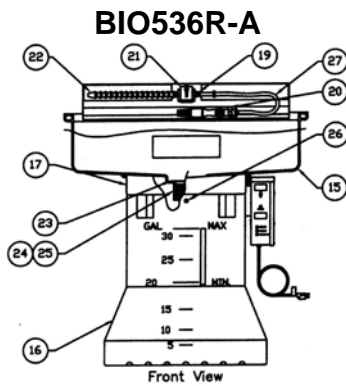
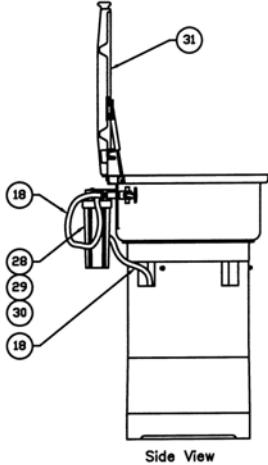
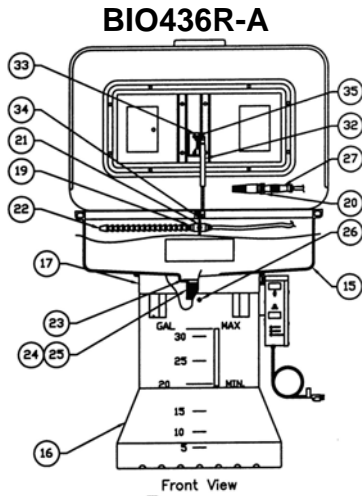

REF	DESCRIPTION	PART NO.	
Electrical Control Assembly Components (Not Shown)	Complete Electrical Control Ass'y	457-40313	
	Toggle Switch (Pump)	770-09192	
	Toggle Switch (Reset)	770-92011	
	Toggle Switch Boot	770-08481	
	Indicator Light – Green	772-92079	
	Indicator Light – Amber	772-92078	
	Indicator Light – Red	772-92080	
	GFCI – 115V	777-09499	
	Float Switch	770-90167	
	Heater	780-90166	
	Pump	390-09663	
	Air Pump	390-92151	
	Tube Bulkhead Compression Fitting	735-91249	
	¼" Air Tubing	729-90678	
	8' Power Cord and Plug	777-04152	
	Relay	782-92066	
	Relay Socket	782-92126	
	Rubber Condensation Guard	744-37878	
	Polyurethane Foam Filter	742-90883	
	3/8" Trim Bulb	603-37983	
Items common to both the BIO436R-A and the BIO536R-A	15	Tank	727-37995-GRAY
	16	Drum	727-37883-GRAY
	17	Ring	727-37995R-GRAY
	18	Black Neoprene Hose	729-90327
	19	Lockline Adapter	728-90796
	20	Gripper Clip	769-90170
	21	3-Way Fluid Valve	738-90795
	22	Flex Hose and Nozzle Assembly	728-90951
	23	Strainer	715-26971-81
	24	Vapor Barrier	742-90144
BIO436R-A Only	25	Filter Cup	742-34222-81
	26	Ring Mounting Thumb Screws	753-04325-81
	27	Flow-Thru Brush with Hose	749-09925
	28	Filter Housing	742-90186
	29	Filter Cartridge	BIOFL1
	30	Filter O-Ring	744-90187
	31	Lid	727-34157-GRAY
	32	Gas Spring Assembly	765-09361
	33	Fuse Link Assembly Bracket	432-34800-81
	34	Linkage Bracket	435-39511-81
	35	Fuse Link Assembly	451-23482
N/A	BIO536R-A Backsplash Assembly	402-38092	

ELECTRICAL SCHEMATIC

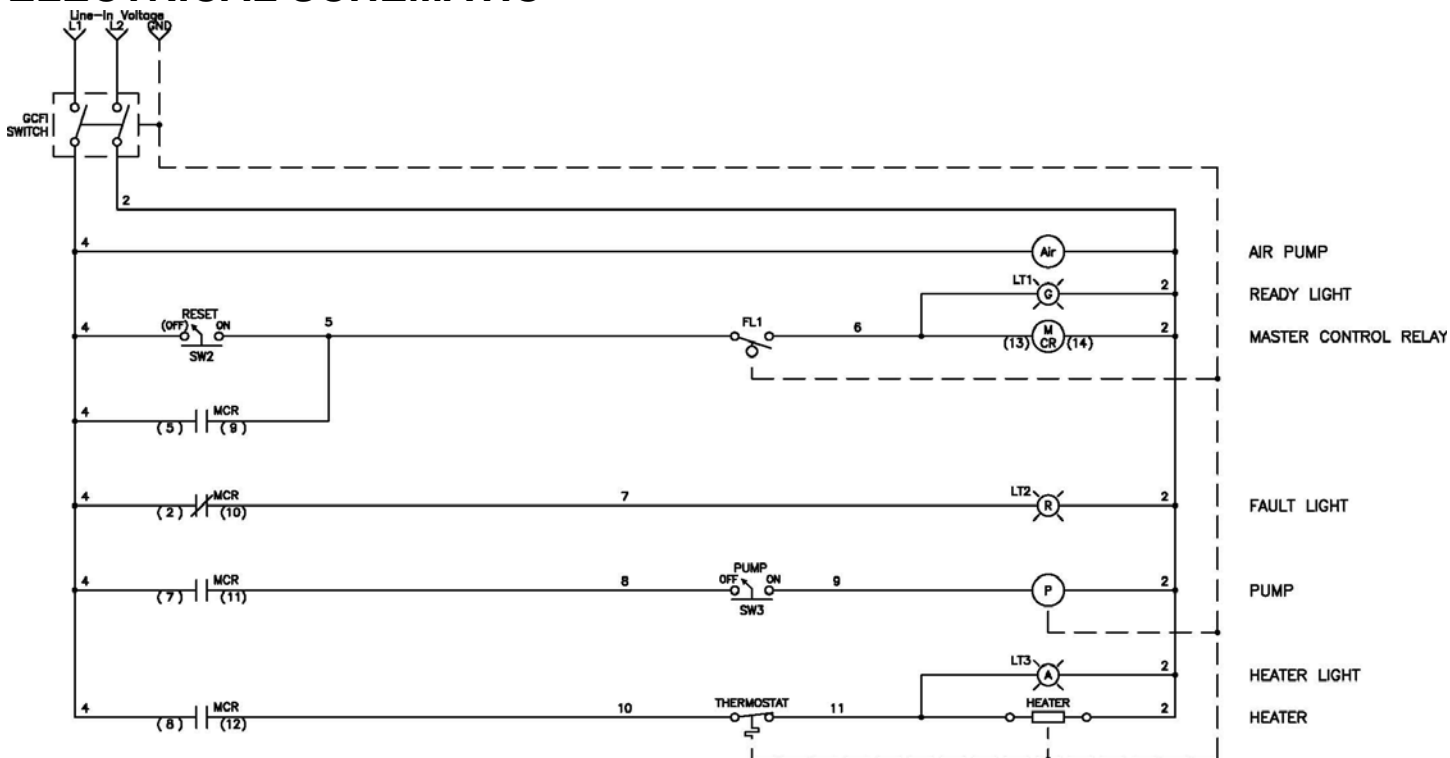

WARRANTY INFORMATION

Graymills Corporation warrants that the equipment manufactured and delivered, when properly installed and maintained, shall be free from defects in workmanship and will function as quoted in the published specification. **Graymills** does not warrant process performance, nor assume any liability for equipment selection, adaptation, or installation.

Warranty does not apply to damages or defects caused by shipping, operator carelessness, misuse, improper application or installation, abnormal use, use of add-on-parts or equipment which damages or impairs the proper function of the unit, and modifications made to the unit. Warranty does not apply to expendable parts needing replacement periodically due to normal wear and tear.

A new Warranty period shall not be established for repaired or replaced materials or products. Such items shall remain under Warranty for only the remainder of the Warranty period of the original material or product.

THE FOREGOING WARRANTIES ARE IN LIEU OF ALL OTHER WARRANTIES, WHETHER ORAL, WRITTEN, EXPRESSED, IMPLIED OR STATUTORY. **GRAYMILLS CORPORATION** MAKES NO OTHER WARRANTY OF ANY KIND, EXPRESS OR IMPLIED. ALL IMPLIED WARRANTIES OF MERCHANTABILITY AND FITNESS FOR A PARTICULAR PURPOSE WHICH EXCEED THE AFORESTATED OBLIGATION ARE HEREBY DISCLAIMED BY **GRAYMILLS CORPORATION** AND EXCLUDED FROM THIS SALE. **Graymills** warranty obligations and Buyer remedies (except to title), are solely and exclusively stated herein. In no case will **Graymills** be liable for consequential damages, loss of production, or any other loss incurred due to interruption of service.

Graymills' obligation under this Warranty shall be limited to:

1. Repairing or replacing (at **Graymills** sole discretion) any non-conforming or defective component within one year from the date of shipment from **Graymills**.
2. Repairing or replacing (at **Graymills** sole discretion), components supplied by, but not manufactured by **Graymills**, to the extent of the warranty given by the original manufacturer.

Buyer must give **Graymills** prompt notice of any defect or failure.

If you believe you have a Warranty claim, contact **Graymills** at (773) 248-6825. Any return material must have an RMA number on the outside of the package and shipping prepaid or shipment will be refused. **Graymills** will promptly examine the material and determine if it is defective and within the Warranty period.